

Production of Specialty Chemicals from a Coal Gasification Acid Gas Waste Stream

Background

A feasibility study is to be performed to investigate the possibility of producing high-value, specialty sulfur chemicals from a sulfur-rich, acid gas waste stream produced by a coal gasification facility. In this facility, a Shell gasifier is used to process approximately 16,000 tons of coal per day into a synthesis gas used primarily to produce higher alcohol oxygenates and fuel additives. The process produces a waste gas stream of 50,000 kg / hr with the following composition:

Carbon Dioxide	62.07 mol %
Hydrogen Sulfide	33.18 mol %
Carbonyl Sulfide	3.34 mol %
Ammonia	0.81 mol %
Methanol	0.56 mol %

The traditional method for the treatment of a waste gas of this type is a sequential application of the Claus and Beavon processes, resulting in elemental sulfur suitable for landfill [1,2]. The goal is to explore the possibility of producing sulfur chemicals from the stream. Bulk chemicals such as sulfuric acid are to be avoided.

The results of the feasibility study show that a reaction method, which is preferred over the Claus and Beavon method, is most profitable. This requires the production of sulfur dioxide via the combustion hydrogen sulfide. The SO_2 is then processed into carbon disulfide, ammonium sulfate, sodium sulfite, and sodium bisulfite. Carbon

disulfide is used in the manufacture of rayon, carbon tetrachloride, soil disinfectants, and as a solvent for phosphorus, sulfur, selenium, bromide, iodine, fats, resins, and rubbers. Ammonium sulfate is used in fertilizers, flame proofing, and galvanization. Sodium sulfite is used in the chemical pulping of wood, water treatment, photography, ore floatation, and textile processing and sodium bisulfite is used as a disinfectant, a bleach, and as a preservative in the bleaching of food.

Process Description

A simplified BFD of the overall process is shown in Figure 1.

Unit 100-Hydrogen Sulfide Separation

The purpose of Unit 100 is to separate hydrogen sulfide from the carbon dioxide in the acid gas waste stream. The PFD for Unit 100 is shown in Figure 2. The acid waste gas enters Unit 100 and is heated. Stream 3 now combines with superheated steam and is sent into a fired heater, H-101. The stream is heated to the reaction temperature, and it then enters an isothermal packed bed reactor, R-101. Here carbonyl sulfide reacts with steam over a titanium oxide catalyst to form hydrogen sulfide and carbon dioxide. Cooled and partially condensed, the reactor effluent is sent to the flash unit, V-101, where the excess steam is removed as condensed water. Stream 16 enters the bottom of absorber T-101 flowing upward countercurrently against the Selexol solvent. The Selexol preferentially absorbs the hydrogen sulfide as opposed to carbon dioxide. The cleaned carbon dioxide leaves the top of the absorber and is sent to Unit 600. The hydrogen sulfide-rich Selexol solvent is preheated in heat exchanger E-106 and sent to distillation column, T-102. In T-102, the Selexol solvent is regenerated, and the absorbed waste gases are sent to absorber T-103. Heat exchanger E-105, using refrigerated water,

reduces the temperature of the recycled Selexol to 25°C. Fresh Selexol is added to the recovered Selexol and enters the top of T-101. The top of T-102 is sent the bottom of a second absorber, T-103, where the stream again flows counter-currently against additional Selexol solvent. Absorber T-103 removes most of the carbon dioxide from the recovered hydrogen sulfide stream. The waste gas (Stream 38) exiting the absorber is sent to Unit 600. The bottom is preheated in two heat exchangers, E-110 and E-111, and is sent to a second distillation column, T-104, where the Selexol solvent is regenerated. The purified hydrogen sulfide leaves Unit 100 and is shared by Units 200 and 500. The bottom stream preheats the tower feed in E-110 and is then pumped up, cooled and combined with fresh Selexol to re-enter T-103.

Unit 200-Carbon Disulfide Production

Figure 3 is the process flow diagram for carbon disulfide production (Unit 200). This process receives hydrogen sulfide (Stream 2) from Unit 100 at a pressure of 300 kPa.

Stream 2 is compressed to a pressure of 350 kPa and is mixed with natural gas (Stream 1). The resulting Stream 4 is then sent to heat exchanger E-201 where it is heated to a temperature of 1060°C. Stream 5 leaving E-201 proceeds to reactive fired heater R-201 where it is heated further to 1100°C. It is attractive to recover the this heat. However, the design of E-201 requires non-conventional techniques, with unusual materials of construction and the inclusion of radiant heat transfer. An alternative for recovering this heat may be attractive. Stream 7 enters heat exchanger E-202 where it is cooled to 50°C (Stream 8) before entering absorber T-201. Absorber T-201 uses Telura-407 (Stream 9); a blend of naphthenic oils sold by Exxon, as the solvent to

remove the carbon disulfide product (CS_2) from Stream 8. The bottom stream exiting T-201 (Stream 11), containing Telura-407, some hydrogen sulfide, and CS_2 , enters distillation column T-202 where the hydrogen sulfide is removed. Stream 14, containing CS_2 and Telura-407, is then sent to a second distillation column, T-204, which removes the Telura-407 (Stream 17) from the CS_2 product (Stream 18). Stream 17 is then recycled back to be mixed with Stream 9 before it enters absorber T-201. The top stream exiting T-201 (Stream 12), containing mostly hydrogen and hydrogen sulfide, is cooled and sent to absorber T-203, which uses monoethanolamine, MEA, (Stream 20) as the solvent to remove the hydrogen in Stream 22. The hydrogen leaves T-203 in Stream 24, leaving MEA and hydrogen sulfide in Stream 23. Stream 23 enters distillation column T-205 where the MEA is removed and recycled back to mix with Stream 20. The top stream exiting T-205, Stream 25, is mixed with Stream 15 leaving the top of T-202 and then sent to Unit 500 to be burned.

Unit 300

A BFD of Unit 300 is shown in Figure 4. In Unit 300, streams of ammonia gas, sulfur dioxide gas, air, and superheated steam are reacted countercurrently in a tray tower with water. The column is comprised of an upper ammonia scrubbing section, a central reaction section and a lower ammonia stripping section. The sulfur dioxide and ammonia streams are introduced into the reacting section of the tower. The air and superheated steam are introduced at the bottom of the reactor. The water is dispersed through the top of the unit. Gas released from the top of the tower is comprised of mostly unreacted sulfur dioxide. The ammonium sulfate slurry descends through the column. At each of the stages in the bottom of the column, a portion of the slurry is extracted and centrifuge

separators separate solid. The liquid from the top of this separation is recycled back into the column for further crystallization. The bottoms product is comprised mostly of an ammonium sulfate aqueous solution. The centrifuge product is crystalline ammonium sulfate. Two forms of the ammonium sulfate product can be produced: an aqueous solution and a crystalline form.

Unit 400-Sodium Sulfite/Bisulfite Production

Sodium sulfite and sodium bisulfite are produced together in Unit 400. A PFD of Unit 400 is shown in Figure 5. The process is carried out in a single absorption tower with a scrubbing section added to the top for better efficiency. Water and sodium carbonate are fed in through the top of the absorption column. Also fed to the top of the column is a sulfur dioxide containing gas being recycled from the bottom that is to be scrubbed. At the bottom of the scrubbing section the waste gases are removed, and the liquids pass into the absorbing section. A liquid seal separates these two sections. Sulfur dioxide gas enters the absorbing section, meets with the downward flowing liquid, and flows into the packing. At the bottom, the gas liquid mixture is conveyed to a receiving tank where the gaseous products are separated and sent to the scrubber section. The liquid removed is a mixture of the two sulfites.

Unit 500-Steam Generation

Figure 6 is the process flow diagram for steam generation. This process receives hydrogen sulfide (H_2S) (Streams 1, 3, and 5) from Units 100 and 200. Stream 3 is the product stream from Unit 100 and contains mainly H_2S . Stream 5 is a waste stream that contains H_2S and water vapor that will be combusted in the fired heater. Stream 1 is a recycle of excess H_2S from Unit 200. These streams are throttled to 130 kPa, mixed to

form Stream 9, and are sent into the fired reactor (R-501) to be combusted. Reactor R-501 operates at a temperature of 600°C and combusts the H₂S to form mainly SO₂, SO₃, and H₂O. Saturated boiler feed water (Stream 14) is pumped up to a pressure of 14,000 kPa in P-501 and vaporized in R-501 to form saturated super-pressure steam at a temperature of approximately 336°C (Stream 16). This super-pressure steam is used in Units 100 and 200. There may be alternatives, such as heat transfer fluids, to using super-pressure steam, which requires very thick walled pipes. The combusted gases from the reactor (Stream 10) are sent through a heat exchanger, E-501. Low-pressure steam (Stream 19) is generated from pumping boiler feed water (Stream 17) to a pressure of 1135 kPa and vaporized at a temperature of 185°C in the shell side of E-501 for use in Unit 200. The process stream leaving E-501 is then divided into Streams 12 and 13 to provide Units 300 and 400 with SO₂ for use in the manufacture of their respective products.

Unit 600-Waste Treatment

Figure 7 is the process flow diagram for waste treatment (Unit 600). This process receives waste gas (Streams 2, 7, and 8) from Units 100, 400, and 300, respectively. Stream 2 arrives from Unit 100, and it contains ammonia which needs to be removed. Stream 8 arrives from Unit 300, and it contains ammonia and sulfur dioxide which need to be removed. Stream 7 arrives from Unit 400, and it contains sulfur dioxide which needs to be removed. Streams 7 and 8 are mixed and sent to a wet lime scrubber, V-601. This scrubber removes the sulfur dioxide and ammonia in these streams, producing ammonium sulfite and calcium sulfite solids. This solid solution (Stream 13) is sent to a disengaging tank (V-602) where most of the liquid is removed from the solids. Air is

added to the disengaging tank to oxidize ammonium sulfite and calcium sulfite to ammonium sulfate and calcium sulfate, respectively. A slurry is removed from the bottom of the tank and dried. Additional equipment needed is not shown. The solids are then sent to landfill, while the liquid is recycled back to the scrubber. Stream 2 is sent to another vessel (V-603), where some of the ammonia in the gas is removed with water. This ammonia solution (Stream 18) is sent back to Unit 300.

Necessary Information and Simulation Hints

The conversion of carbonyl sulfide to hydrogen sulfide was accomplished through a carbonyl sulfide hydrolysis reaction. The design for the hydrolysis reactor was based on work done by Tong et al. [3] in the area of kinetic modeling of the hydrolysis of carbonyl sulfide.

The Selexol process is a patented process invented by Allied Chemical Corporation in 1969. Currently, Union Carbide is registered as the sole assignee of the patent and the trademark for the Selexol process. Selexol is a mixture of polyethylene glycol dimethyl ethers with the following chemical formula:



The x in the above formula will typically range from three to nine. The Selexol solvent was modeled using solubility data [4,5].

The separation of hydrogen sulfide from carbon dioxide is accomplished by a series of two absorption / regeneration steps: (1) moderate pressure absorption / regeneration followed by (2) low-pressure absorption / regeneration.

The reaction kinetics for the reaction of methane and hydrogen sulfide to produce carbon disulfide and hydrogen were obtained from work done by the Institute of Gas

Technology [6]. Using a catalyst provided by IGT, if the ratio of hydrogen sulfide to methane is 4:1, and if the reaction takes place at a temperature of at least 1100°C, then a 50% conversion of hydrogen sulfide and a 100% conversion of methane is achieved. This catalyst is under development by IGT, therefore, unofficial projections by IGT were used for catalyst density, life, and cost. The bulk catalyst density used in the calculations was 950 kg/m³ with a five year operating life and a cost of \$200,000.

. The reaction for the production of ammonium sulfate is [7]:

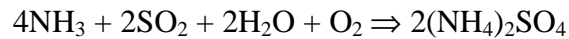

The reactions involved with producing sodium sulfite and sodium bisulfite are [8]:

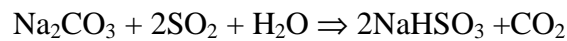
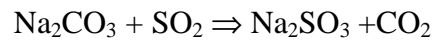

Equipment Descriptions

E-101	Effluent Cooler
E-102	Heat Exchanger (Heating)
E-103	Heat Exchanger (Heating)
E-104	Heat Exchanger (Heating)
E-105	Tower Preheater
E-106	Tower Preheater
E-107	Effluent Cooler
E-108	Reboiler
E-109	Reboiler
E-110	Heat Exchanger (Heating)
E-111	Heat Exchanger (Heating)

E-112	Condenser
E-113	Reboiler
E-114	Effluent Cooler
E-115	Effluent Cooler
H-101	Fired Heater
P-101	Recycle Pump
P-102	Reflux Pump
P-103	Reflux Pump
P-104	Recycle Pump
R-101	Packed Bed Reactor
T-101	Medium Pressure Absorber
T-102	Low Pressure Absorber
T-103	Selexol Distillation Column
T-104	Selexol Distillation Column
V-101	Flash Vessel
V-102	Reflux Vessel
V-103	Reflux Vessel
C-201	Feed Compressor
E-201	Reactor Preheater
E-202	Gas Cooler
E-203	Partial Condenser
E-204	Thermosiphon Reboiler
E-205	Total Condenser

E-206	Thermosiphon Reboiler
E-207	Telura-407 Cooler
E-208	Gas Cooler
E-209	Partial Condenser
E-210	Thermosiphon Reboiler
E-211	MEA Cooler
P-201A/B	Pump
P-202A/B	Reflux Pump
P-203A/B	Reflux Pump
P-204A/B	Recycle Pump
P-205A/B	Reflux Pump
R-201	Reactive Fired Heater
T-201	Carbon Disulfide Absorber
T-202	Hydrogen Sulfide Tower
T-203	Hydrogen Sulfide Absorber
T-204	Product Tower
T-205	MEA Tower
V-201	Knockout Drum
V-202	Reflux Drum
V-203	Knockout Drum
C-501	Air Compressor
E-501	Heat Exchanger
P-501A/B	BFW Pump

P-502A/B	BFW Pump
R-501	Incinerator
C-601	Air Compressor
P-601A/B	Slurry Pump
V-601	Wet Lime Scrubber
V-602	Disengaging Tank
V-603	Ammonia Scrubber

References

1. Kohl, A. and F. Riesenfeld, *Gas Purification 4th ed.*, Gulf Publishing, Houston, TX, 1985. pp. 446-451, 739-753.
2. Kohl, A. and F. Riesenfeld, *Gas Purification 4th ed.*, Gulf Publishing, Houston, TX, 1985. pp. 739-743.
3. Tong, S., I.G. Dalla Lana, and K.T. Chuang, "Kinetic Modelling of the Hydrolysis of Carbonyl Sulfide Catalyzed by Either Titania or Alumina," *The Canadian Journal of Chemical Engineering*, **71** (3), 392-400 (1993).
4. U.S. Patent # 3,594,985 Acid Gas Removal From Gas Mixtures.
5. McKetta, J.J. *Encyclopedia of Chemical Processing Design*, Vol. 52., Marcel Dekker Inc., New York, 1995, pp.458-472.
6. Erekson, "Gasoline from Natural Gas by Sulfur Processing," 1995 Coal Liquefaction and Gas Conversion Contractors Review Conference.
7. U.S. Patent # 4,250,160 Process for Manufacture of Ammonium Sulfate.
8. U.S. Patent # 5,266,296 Cocurrent Flow Process for the Manufacture of Sodium Sulfite and Bisulfite Solutions.

Unit 100-Hydrogen Sulfide Separation Unit

Stream	1	2	3	4	5	6	7	8	9	10
Temp. (°C)	25	320	320	320	330	330	60.5	20	20	20
Press. (kPa)	2615	2600	2600	2600	2590	2575	2560	2084	2084	2084
Vapor Fraction	1	1	1	1	1	1	0.98	0.97	--	1
Total Flow (kg/h)	49830	1081	49830	50911	50911	50911	50911	50911	958	49952
Total Flow (kmol/h)	1218	60	1218	1278	1278	1278	1278	1278	36.3	1241.8
Component Flows (kmol/h)										
Ammonia	9.7	--	9.7	9.7	9.7	9.7	9.7	9.7	0.7	9.0
Carbon Dioxide	758.7	--	758.7	758.7	758.7	795.6	795.6	795.6	10.5	785.1
Carbonyl Sulfide	37.2	--	37.2	37.2	37.2	0.3	0.3	0.3	--	0.3
Hydrogen Sulfide	405.6	--	405.6	405.6	405.6	442.5	442.5	442.5	0.1	442.4
Methanol	6.8	--	6.8	6.8	6.8	6.8	6.8	6.8	2.2	4.6
Selexol	--	--	--	--	--	--	--	--	--	--
Water	--	60.0	--	60.0	60.0	23.1	23.1	23.1	22.7	0.4

Stream	11	12	13	14	15	16	17	18	19
Temp. (°C)	-2.4	35	-6	30	-6	25	25	29.5	47.5
Press. (kPa)	1800	1790	1300	1290	780	770	760	760	770.1
Vapor Fraction	0.98	1	0.99	1	0.99	1	--	1	--
Total Flow (kg/h)	49952	49952	49952	49952	49952	49952	189002	26854	212100
Total Flow (kmol/h)	1241.8	1241.8	1241.8	1241.8	1241.8	1241.8	1890	610.3	2521.5
Component Flows (kmol/h)									
Ammonia	9.0	9.0	9.0	9.0	9.0	9.0	--	0.4	8.6
Carbon Dioxide	785.1	785.1	785.1	785.1	785.1	785.1	--	609.7	175.4
Carbonyl Sulfide	0.3	0.3	0.3	0.3	0.3	0.3	--	0.1	0.2
Hydrogen Sulfide	442.4	442.4	442.4	442.4	442.4	442.4	--	0.1	442.4
Methanol	4.6	4.6	4.6	4.6	4.6	4.6	--	--	4.6
Selexol	--	--	--	--	--	--	1890.0	0.1	1889.9
Water	0.4	0.4	0.4	0.4	0.4	0.4	--	--	0.4

Stream	20	21	22	23	24	25	26	27	28
Temp. (°C)	43.2	260	321.6	302.6	49.5	49.8	40	37.3	34.9
Press. (kPa)	412	404	408	408	398	800	800	790	780
Vapor Fraction	0.05	0.4	--	--	--	--	--	--	--
Total Flow (kg/h)	212100	212100	188974	188974	188974	188974	188974	188974	188974
Total Flow (kmol/h)	2521.5	2521.5	1889.7	1889.7	1889.7	1889.7	1889.7	1889.7	1889.7
Component Flows (kmol/h)									--
Ammonia	8.6	8.6	--	--	--	--	--	--	--
Carbon Dioxide	175.4	175.4	--	--	--	--	--	--	--
Carbonyl Sulfide	0.2	0.2	--	--	--	--	--	--	--
Hydrogen Sulfide	442.4	442.4	--	--	--	--	--	--	--
Methanol	4.6	4.6	--	--	--	--	--	--	--
Selexol	1889.9	1889.9	1889.7	1889.7	1889.7	1889.7	1889.7	1889.7	1889.7
Water	0.4	0.4	--	--	--	--	--	--	--

Stream	29	30	31	32	33	34	35	36	37
Temp. (°C)	33	25	25	25	25	25	46.5	46.2	25
Press. (kPa)	770	760	760	760	760	390	400	395.1	390
Vapor Fraction	--	--	--	--	--	--	1	1	--
Total Flow (kg/h)	188974	188974	29	28	2	2	23126	23126	171298
Total Flow (kmol/h)	1889.7	1889.7	0.5	0.3	0.2	0.2	631.8	631.8	1713
Component Flows (kmol/h)									
Ammonia	--	--	--	--	--	--	8.6	8.6	--
Carbon Dioxide	--	--	--	--	--	--	175.4	175.4	--
Carbonyl Sulfide	--	--	--	--	--	--	0.2	0.2	--
Hydrogen Sulfide	--	--	--	--	--	--	442.4	442.4	--
Methanol	--	--	--	--	--	--	4.6	4.6	--
Selexol	1889.7	1889.7	0.5	0.3	0.2	0.2	0.2	0.2	1713
Water	--	--	--	--	--	--	0.4	0.4	--

Stream	38	39	40	41	42	43	44	45	46
Temp. (°C)	27.7	54.6	54.3	257.8	264.5	44.7	306.1	59.3	59.3
Press. (kPa)	390	395.1	385.1	347.1	311.1	300	320	310	410
Vapor Fraction	1	--	--	0.3	0.4	1	--	--	--
Total Flow (kg/h)	6544	187880	187880	187880	187880	16584	171296	171296	171296
Total Flow (kmol/h)	148.7	2196.1	2196.1	2196.1	2196.1	483.1	1712.9	1712.9	1712.9
Component Flows (kmol/h)									
Ammonia	--	8.6	8.6	8.6	8.6	8.6	--	--	--
Carbon Dioxide	148.7	26.8	26.8	26.8	26.8	26.8	--	--	--
Carbonyl Sulfide	--	0.2	0.2	0.2	0.2	0.2	--	--	--
Hydrogen Sulfide	--	442.4	442.4	442.4	442.4	442.4	--	--	--
Methanol	--	4.6	4.6	4.6	4.6	4.6	--	--	--
Selexol	--	1713.0	1713.0	1713.0	1713.0	1713.0	1712.9	1712.9	1712.9
Water	--	0.4	0.4	0.4	0.4	0.4	--	--	--

Stream	47	48	49	50	51
Temp. (°C)	40	25	44.7	44.7	24.3
Press. (kPa)	400	390	300	300	390
Vapor Fraction	--	--	1	1	1
Total Flow (kg/h)	171296	171296	12438	4146	33398
Total Flow (kmol/h)	1712.9	1712.9	362.4	120.7	759
Component Flows (kmol/h)					
Ammonia	--	--	6.4	2.2	0.4
Carbon Dioxide	--	--	20.1	6.7	758.4
Carbonyl Sulfide	--	--	0.15	0.05	0.1
Hydrogen Sulfide	--	--	331.7	110.6	0.1
Methanol	--	--	3.4	1.2	--
Selexol	1712.9	1712.9	trace	trace	0.1
Water	--	--	0.3	0.1	--

Unit 200-Carbon Disulfide Production

Stream	1	2	3	4	5	6	7	8
Temp. (°C)	81.4	45	60.7	65.1	1060	1100	220.2	50
Press. (kPa)	500	300	350	350	330	300	300	280
Vapor Fraction	1	1	1	1	1	1	1	1
Total Flow (kmol/h)	36.8	140.99	140.99	177.79	177.79	242.39	242.39	242.39
Total Flow (kg/h)	667.81	4835.94	4835.94	5503.75	5503.75	5503.75	5503.75	5503.75
Component Flows (kmol/h)								
Ammonia	--	2.510	2.510	2.510	2.510	2.510	2.510	2.510
Carbon Dioxide	--	7.830	7.830	7.830	7.830	7.830	7.830	7.830
Carbon Disulfide	--	--	--	--	--	32.300	32.300	32.300
Ethane	1.840	--	--	--	--	1.840	1.840	1.840
Hydrogen	--	--	--	--	--	129.200	129.200	129.200
Hydrogen Sulfide	--	129.200	129.200	129.200	129.200	64.600	64.600	64.600
Methane	33.120	--	--	--	--	0.820	0.820	0.820
Methanol	--	1.340	1.340	1.340	1.340	1.340	1.340	1.340
Monoethanolamine	--	--	--	--	--	--	--	--
Propane	1.840	--	--	--	--	1.840	1.840	1.840
Telura-407	--	--	--	--	--	--	--	--
Water	--	0.113	0.113	0.113	0.113	0.113	0.113	0.113

Stream	9	10	11	12	13	14	15	16
Temp. (°C)	25	50	57.8	50.8	57.8	162.8	37.4	159.3
Press. (kPa)	260	260	280	280	350	370	350	120
Vapor Fraction	--	--	--	1	--	--	1	0.12
Total Flow (kmol/h)	0.11	155.01	189.88	207.52	189.88	186.21	3.67	186.21
Total Flow (kg/h)	26.45	37275.3	39871.6	2997.35	39871.6	39649.6	132.04	29649.6
Component Flows (kmol/h)								
Ammonia	--	--	0.010	2.500	0.010	--	0.010	--
Carbon Dioxide	--	--	0.003	7.827	0.003	--	0.003	--
Carbon Disulfide	--	--	31.300	1.000	31.300	31.200	0.100	31.200
Ethane	--	--	--	1.840	--	--	--	--
Hydrogen	--	--	--	129.200	--	--	--	--
Hydrogen Sulfide	--	--	31.500	61.450	3.150	--	3.150	--
Methane	--	--	--	0.82	--	--	--	--
Methanol	--	--	0.260	1.080	0.260	0.001	0.259	0.001
Monoethanolamine	--	--	--	--	--	--	--	--
Propane	--	--	0.150	1.690	0.150	--	0.150	--
Telura-407	0.110	155.010	155.000	0.002	155.000	155.000	--	155.000
Water	--	--	0.002	0.111	0.002	--	0.002	--

Stream	17	18	19	20	21	22	23	24
Temp. (°C)	319	52.7	319.2	35	35	35	71.96	35.1
Press. (kPa)	140	110	280	220	220	240	240	220
Vapor Fraction	--	--	--	--	--	1	--	1
Total Flow (kmol/h)	154.85	31.36	154.85	0.17	149.41	207.52	223.35	133.59
Total Flow (kg/h)	37237.9	2411.72	37237.9	10.38	9117.64	2997.35	11707.5	407.54
Component Flows (kmol/h)								
Ammonia	--	--	--	--	--	2.500	2.500	--
Carbon Dioxide	--	--	--	--	0.320	7.830	8.150	--
Carbon Disulfide	--	31.200	--	--	--	1.000	1.000	--
Ethane	--	--	--	--	--	1.840	--	1.840
Hydrogen	--	--	--	--	--	129.200	0.004	129.200
Hydrogen Sulfide	--	--	--	--	0.090	61.450	61.450	--
Methane	--	--	--	--	--	0.820	--	0.820
Methanol	--	0.001	--	--	--	1.080	1.080	--
Monoethanolamine	--	--	--	0.170	149.000	--	148.960	0.040
Propane	--	--	--	--	--	1.690	--	1.690
Telura-407	154.850	0.155	154.850	--	--	0.002	0.002	--
Water	--	--	--	--	0.002	0.111	0.126	--

Stream	25	26	27	28	29	30
Temp. (°C)	87.5	84.4	199.5	199.5	35	50
Press. (kPa)	240	240	260	240	220	260
Vapor Fraction	1	1	--	--	--	--
Total Flow (kmol/h)	74.1	77.75	149.24	149.24	149.24	154.9
Total Flow (kg/h)	2600.33	2732.38	9107.25	9107.25	9107.25	37237.9
Component Flows (kmol/h)						
Ammonia	2.500	3.510	--	--	--	--
Carbon Dioxide	7.830	7.830	0.320	0.320	0.320	--
Carbon Disulfide	1	1.100	--	--	--	--
Ethane	--	--	--	--	--	--
Hydrogen	0.004	0.004	--	--	--	--
Hydrogen Sulfide	61.450	64.600	0.090	0.090	0.090	--
Methane	--	--	--	--	--	--
Methanol	1.080	1.340	--	--	--	--
Monoethanolamine	0.130	0.130	148.830	148.830	148.830	--
Propane	--	0.150	--	--	--	--
Telura-407	0.002	0.003	--	--	--	154.900
Water	0.111	0.113	0.002	0.002	0.002	--

Unit 500-Steam Generation

Stream	1	2	3	4	5	6	7	8	9	10
Temp. (°C)	84.4	78.1	44.7	34.4	20	3.22	25	53.2	19.3	600
Press. (kPa)	240	130	300	130	2084	130	101	130	130	110
Vapor Fraction	1	1	1	1	0.27	0.31	1	1	0.96	1
Total Flow (kg/h)	2731	2731	11749	11749	959	959	95208	95208	15439	110702
Total Flow (kmol/h)	77.74	77.74	342.09	342.09	36.29	36.29	3300	3300	456.2	3570
Component Flows (kmol/h)										
Ammonia	2.51	2.51	6.11	6.11	0.72	0.72	--	--	9.34	--
Carbon Dioxide	7.83	7.83	18.98	18.98	10.51	10.51	--	--	37.32	51.3
Carbon Disulfide	1.10	1.10	--	--	--	--	--	--	1.10	--
Carbonyl Sulfide	--	--	0.21	0.21	--	--	--	--	0.22	--
Ethane	--	--	--	--	--	--	--	--	--	--
Hydrogen	--	--	--	--	--	--	--	--	--	--
Hydrogen Sulfide	64.60	64.60	313.07	313.07	0.09	0.09	--	--	377.75	--
Methanol	1.34	1.34	3.27	3.27	2.23	2.23	--	--	6.84	--
Monoethanolamine	0.10	0.10	--	--	--	--	--	--	0.10	--
Nitrogen	--	--	--	--	--	--	2607	2607	--	2612.0
Oxygen	--	--	--	--	--	--	693	693	--	98.5
Propane	0.15	0.15	--	--	--	--	--	--	0.15	--
Selexol	--	--	0.17	0.17	--	--	--	--	0.17	--
Sulfur Dioxide	--	--	--	--	--	--	--	--	--	376.4
Sulfur Trioxide	--	--	--	--	--	--	--	--	--	3.8
Water	0.11	0.11	0.28	0.28	22.74	22.74	--	--	23.11	428.0

Stream	11	12	13	14	15	16	17	18	19
Temp. (°C)	242	242	242	336	336	336	186	186	186
Press. (kPa)	100	100	100	13800	14000	14000	560	1145	1135
Vapor Fraction	1	1	1	--	--	1	--	--	1
Total Flow (kg/h)	110702	99603	11099	136000	136000	136000	18000	18000	18000
Total Flow (kmol/h)	3570	2313	357	7555.56	7555.56	7555.56	1000	1000	1000
Component Flows (kmol/h)									
Ammonia	--	--	--	--	--	--	--	--	--
Carbon Dioxide	51.30	46.17	5.13	--	--	--	--	--	--
Carbon Disulfide	--	--	--	--	--	--	--	--	--
Carbonyl Sulfide	--	--	--	--	--	--	--	--	--
Ethane	--	--	--	--	--	--	--	--	--
Hydrogen	--	--	--	--	--	--	--	--	--
Hydrogen Sulfide	--	--	--	--	--	--	--	--	--
Methanol	--	--	--	--	--	--	--	--	--
Monoethanolamine	--	--	--	--	--	--	--	--	--
Nitrogen	2612.00	2351.00	261.00	--	--	--	--	--	--
Oxygen	98.50	88.65	9.85	--	--	--	--	--	--
Propane	--	--	--	--	--	--	--	--	--
Selexol	--	--	--	--	--	--	--	--	--
Sulfur Dioxide	376.40	338.76	37.64	--	--	--	--	--	--
Sulfur Trioxide	3.80	3.42	0.38	--	--	--	--	--	--
Water	428.00	385.00	43.00	7555.56	7555.56	7555.56	1000	1000	1000

Unit 600-Waste Treatment

Stream	1	2	3	4	5	6	7	8	9
Temp. (°C)	25	24.3	24.3	25	25	25	25	25	25
Press. (kPa)	120	390	140	101	101	117	120	120	120
Vapor Fraction	--	1	1	--	1	1	1	1	1
Total Flow (kg/h)	216	334393.3	33439.3	348.42	1115.8	1115.8	7520	42400	49920
Total Flow (kmol/h)	12	759	759	8.57	38.69	38.69	254.47	1490.45	1744.92
Component Flows (kmol/h)									
Ammonia	--	0.4	0.4	--	--	--	--	5.88	5.88
Ammonium Sulfate	--	--	--	--	--	--	--	--	--
Ammonium Sulfite	--	--	--	--	--	--	-	--	--
Calcium Oxide	--	--	--	5.11	--	--	--	--	--
Calcium Sulfate	--	--	--	--	--	--	--	--	--
Carbon Dioxide	--	758.4	758.4	--	--	--	20.45	38.64	59.09
Carbonyl Sulfide	--	0.1	0.1	--	--	--	--	--	--
Hydrogen Sulfide	--	0.1	0.1	--	--	--	--	--	--
Nitrogen	--	--	--	--	30.57	30.57	232.14	1428.57	1660.71
Oxygen	--	--	--	--	8.12	8.12	--	--	--
Selexol	--	0.1	0.1	--	--	--	--	--	--
Sulfur Dioxide	--	--	--	--	--	--	1.88	6.25	8.13
Water	12	--	--	3.46	--	--	--	11.11	11.11

Stream	10	11	12	13	14	15	16	17	18
Temp. (°C)	25	25	25	25	25	25	25	25	25
Press. (kPa)	100	100	110	120	101	101	101	120	140
Vapor Fraction	--	--	1	--	--	1	--	1	--
Total Flow (kg/h)	401	400.74	49101.5	1068.8	52.3	1011.6	1119.6	33416.2	196.44
Total Flow (kmol/h)	9.9	9.85	1719.89	12.79	1.28	36.06	10.08	760.18	10.92
Component Flows (kmol/h)									
Ammonia	--	--	0.01	--	--	--	--	0.28	0.12
Ammonium Sulfate	--	--	--	--	--	--	2.94	--	--
Ammonium Sulfite	--	--	--	2.94	--	--	--	--	--
Calcium Oxide	5.90	5.88	--	0.77	0.77	--	--	--	--
Calcium Sulfate	--	--	--	--	--	--	5.11	--	--
Carbon Dioxide	--	--	59.09	5.11	--	--	--	758.40	--
Carbonyl Sulfide	--	--	--	--	--	--	--	0.10	--
Hydrogen Sulfide	--	--	--	--	--	--	--	0.10	--
Nitrogen	--	--	1660.71	--	--	30.57	--	--	--
Oxygen	--	--	--	--	--	4.06	--	--	--
Selexol	--	--	--	--	--	--	--	0.10	--
Sulfur Dioxide	--	--	0.08	--	--	--	--	--	--
Water	4.00	3.97	--	3.97	0.51	1.43	2.03	1.20	10.80

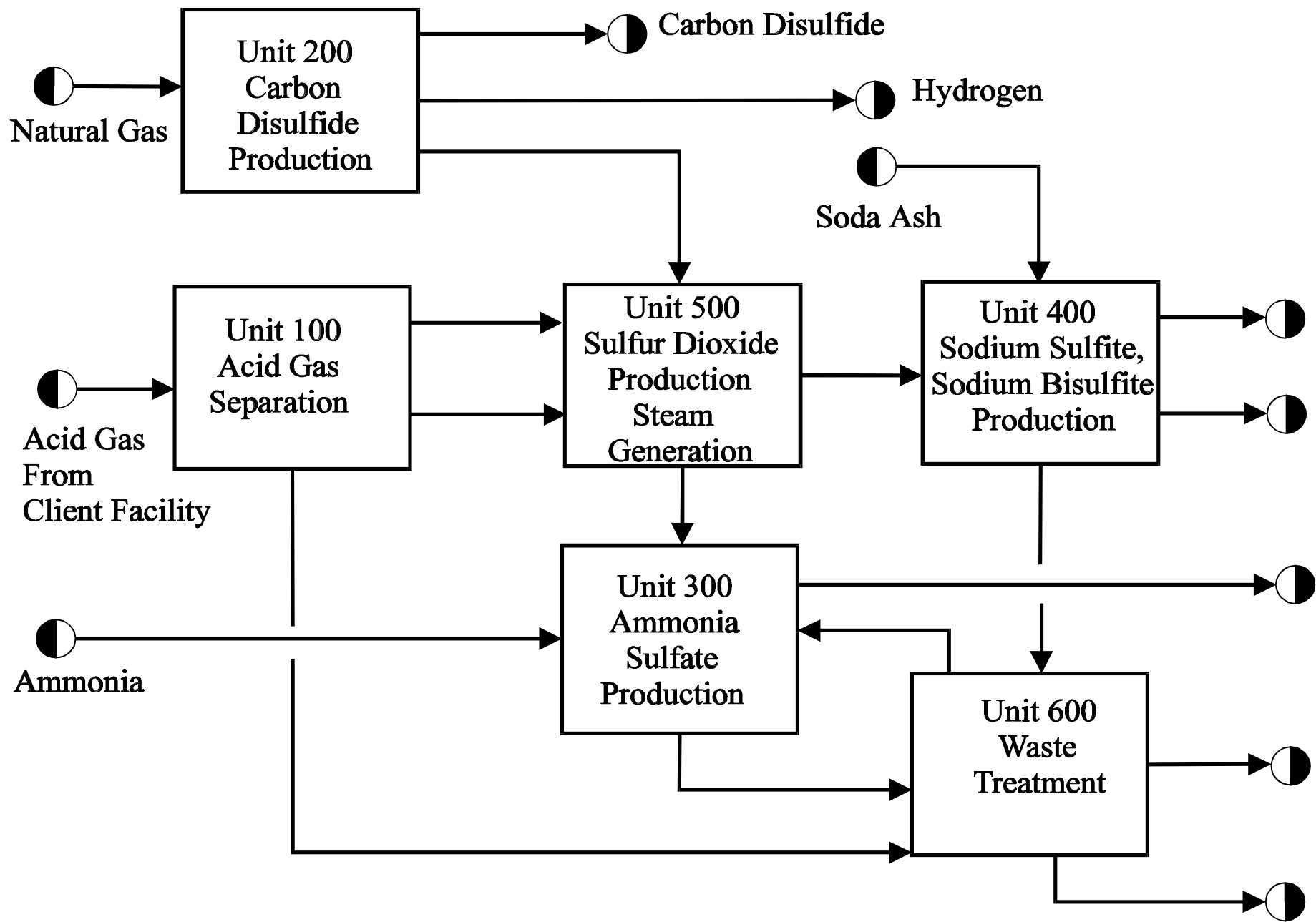

Figure 1: BFD of Specialty Sulfur Chemicals

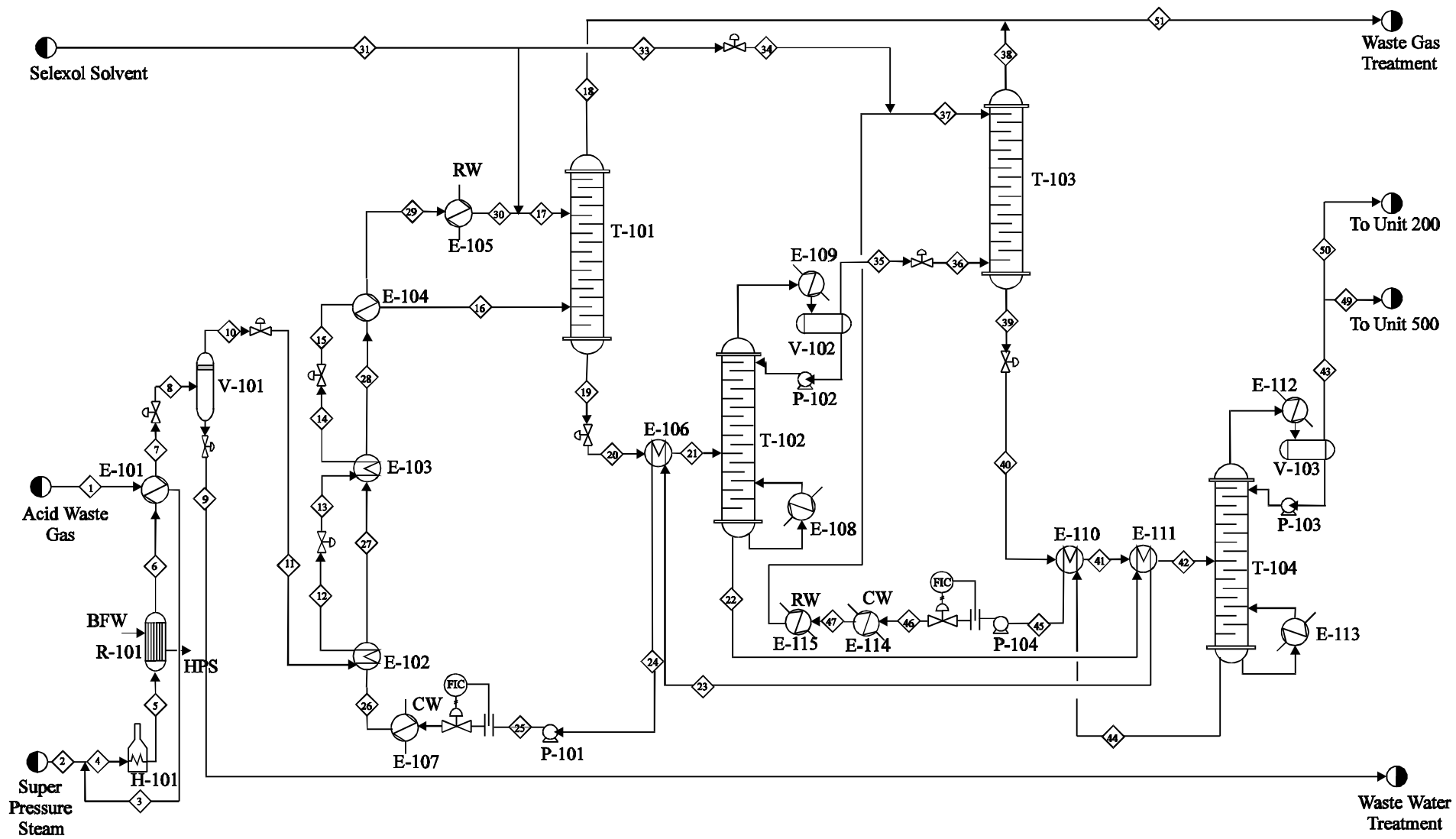

Figure 2: PFD for Unit 100--Hydrogen Sulfide Separation

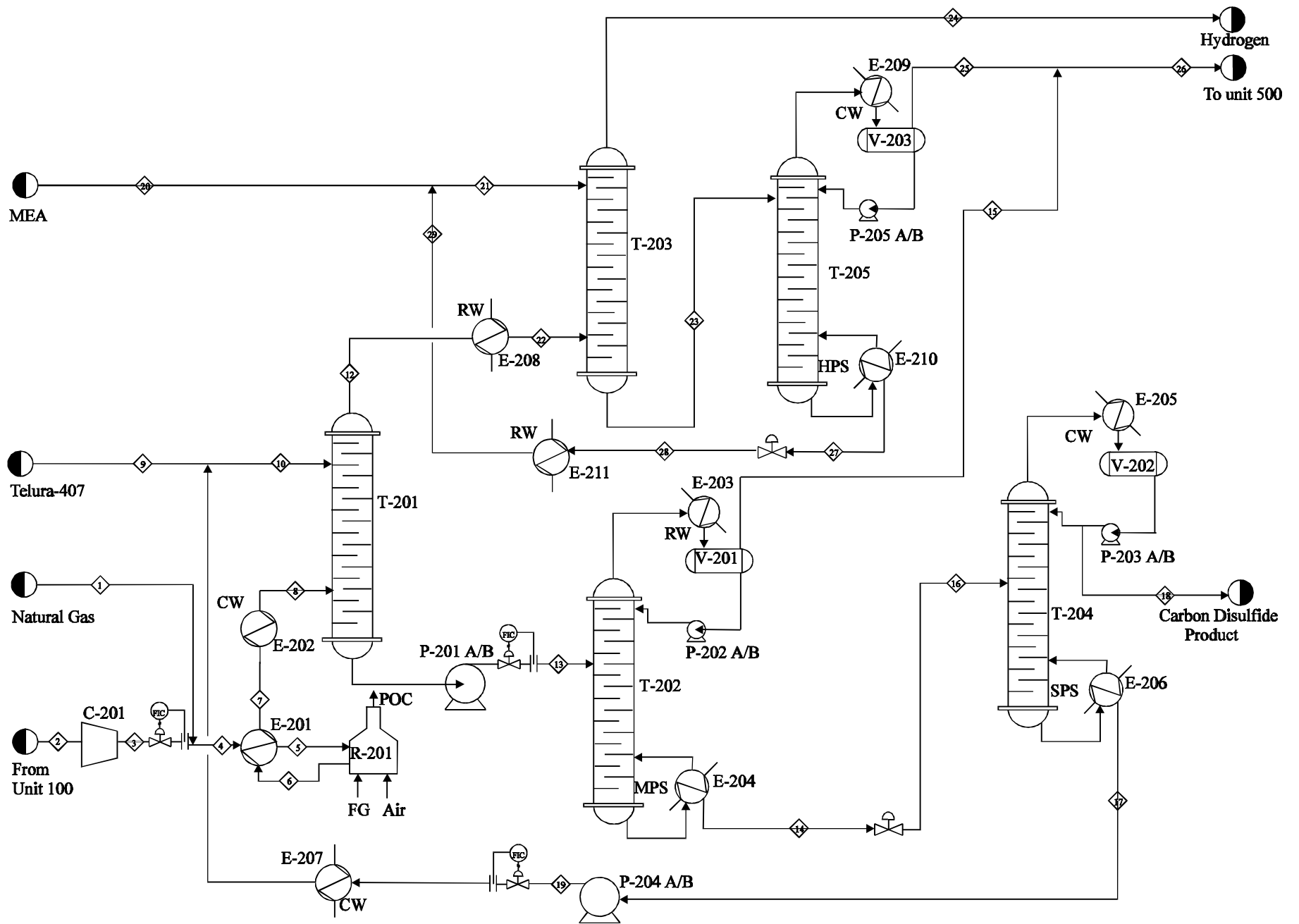

Figure 3: PFD for Unit 200--Carbon Disulfide Production

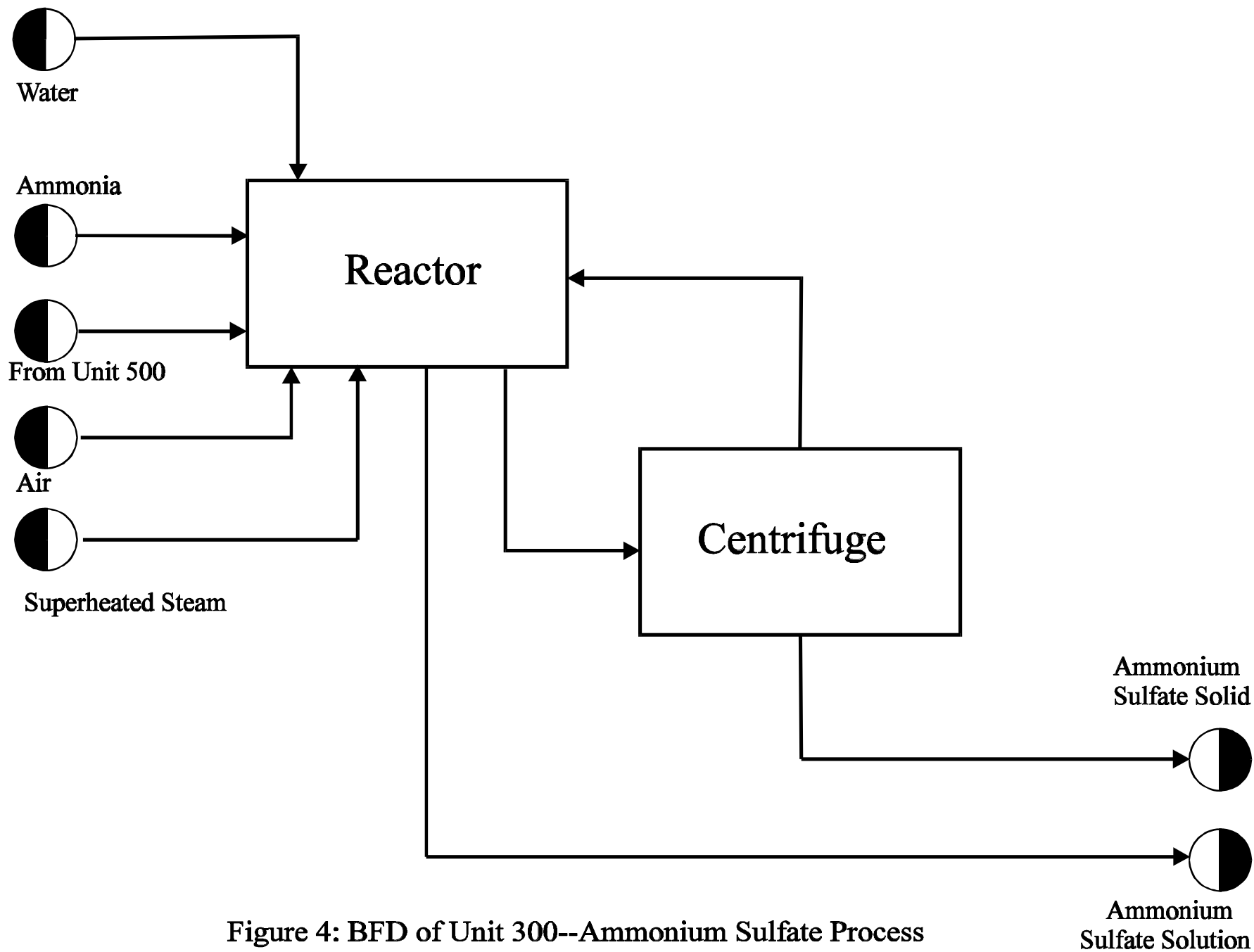

Figure 4: BFD of Unit 300--Ammonium Sulfate Process

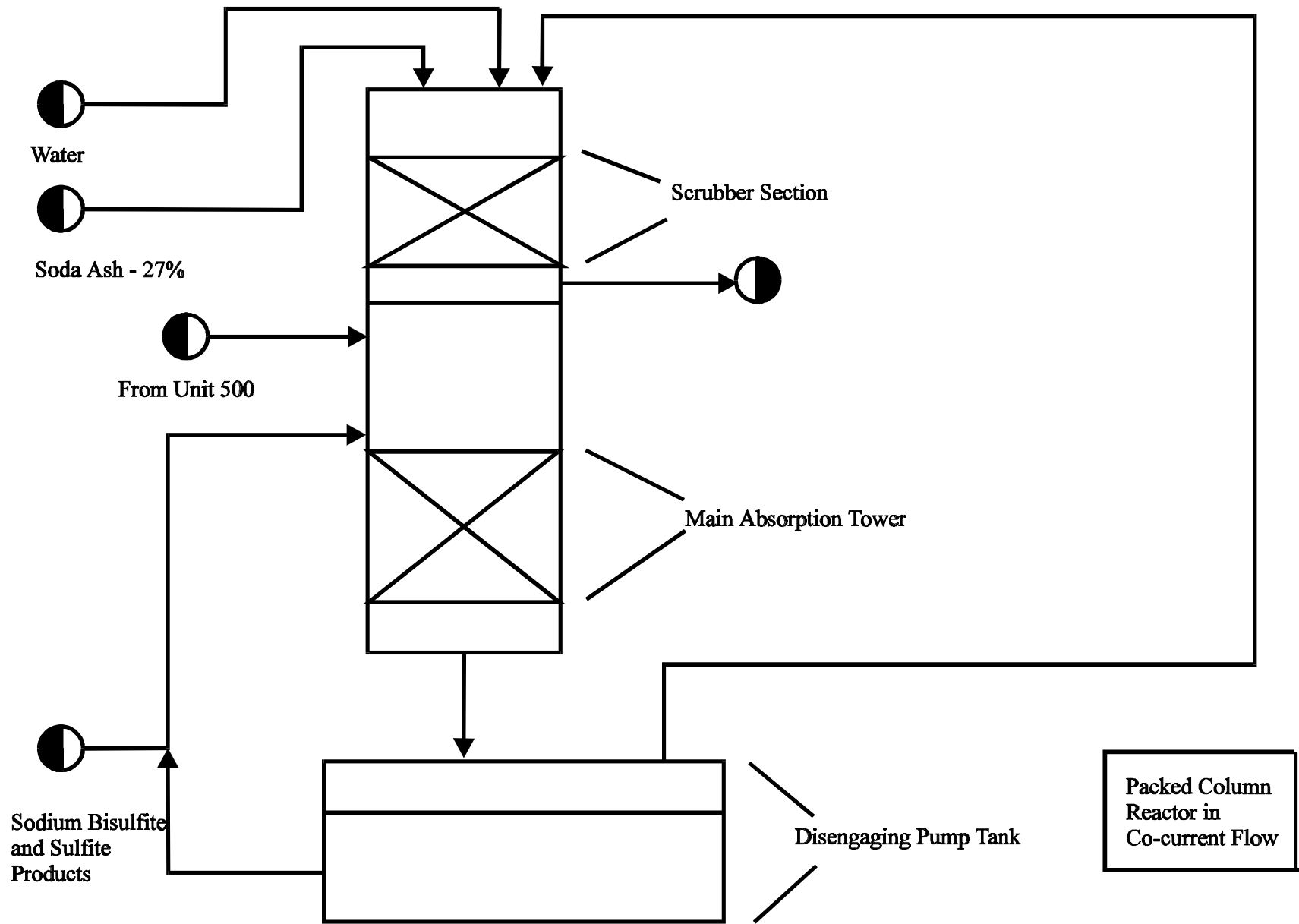

Figure 5: PFD of Unit 400 -- Sodium Sulfite/Bisulfite Production

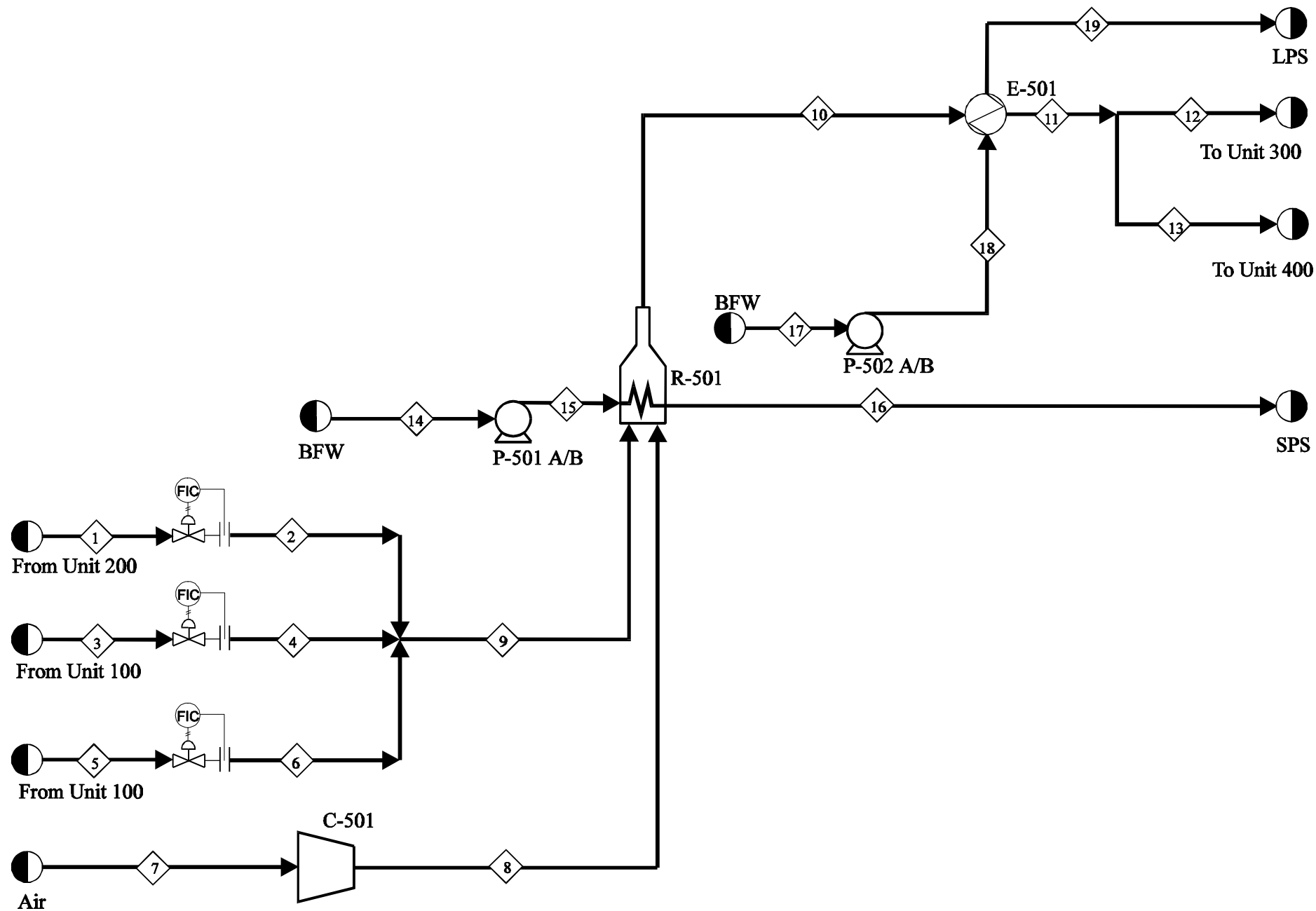

Figure 6: PFD for Unit 500--Steam Generation

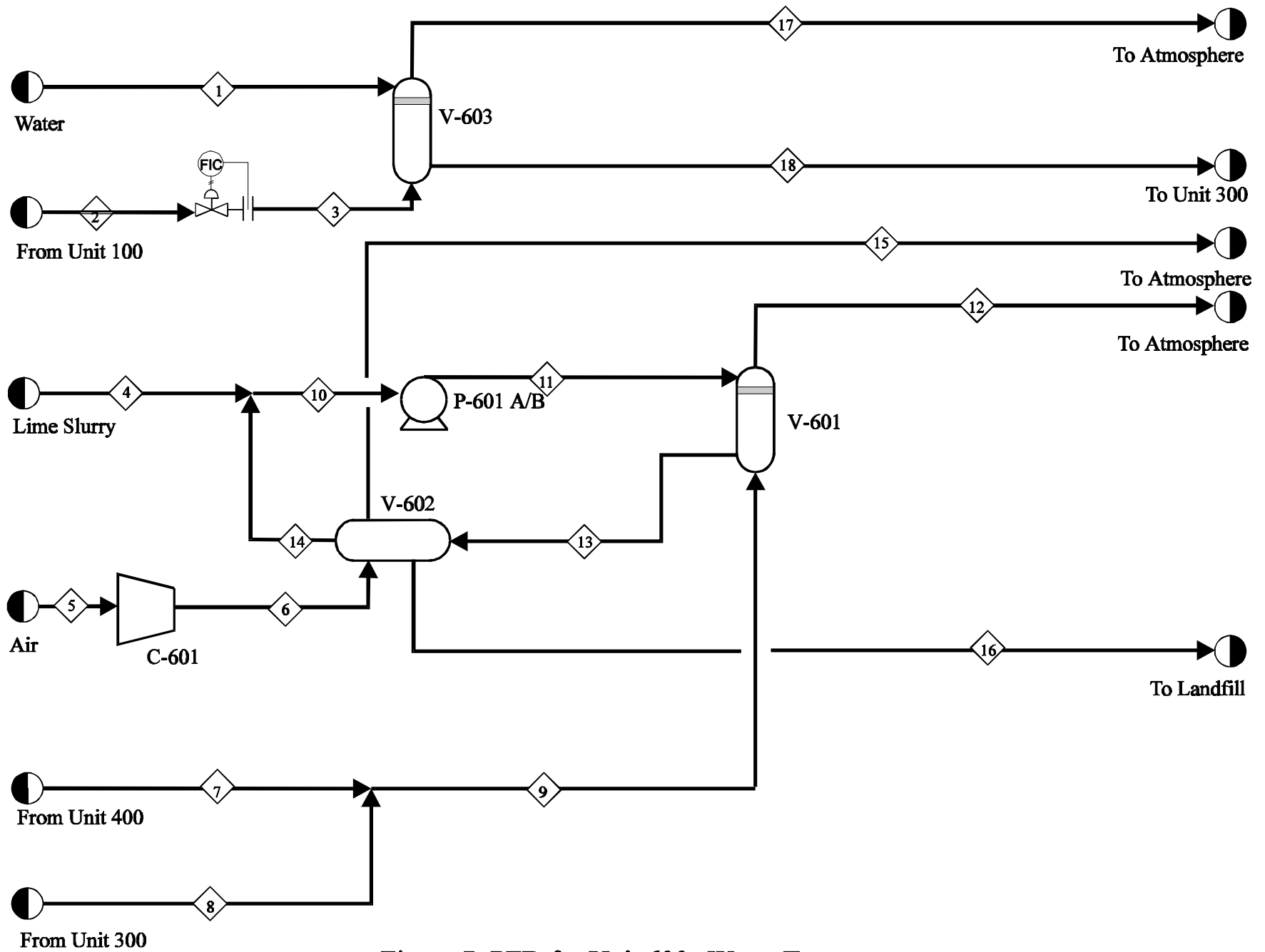

Figure 7: PFD for Unit 600--Waste Treatment